

ADA/BARRIER FREE SHOWERS

36" ADA TRANSFER SHOWERS

60" ADA ROLL-IN SHOWERS

NOTE: INSTALLATION OF THESE SHOWER UNITS MAY BE SUBJECT TO CODE APPROVAL

Refer to job prints and/or consult with architect to see if your installation must comply with ADA.

These shower units install differently from typical residential showers. Installation may need to conform to requirements of the Americans With Disabilities Act (ADA) and other local codes. These requirements relate to the height of the threshold in relation to the finished floor. Certain showers will install directly on the sub floor and others will require a recess or pit. These showers require special preparation of the installation site, and very specific installation procedures to assure the shower drains properly and meets code requirements.

QUESTIONS? Please phone: 1-877-947-7769 for additional information.

STORAGE AND HANDLING

1. Most handling damage is the result of impact blows to the back side of the shower units.
2. Stress cracks can develop when shipping boards are removed before unit is positioned for final installation in bathroom.
3. Placing objects inside of tub can cause scratches, abrasions or nicks to the finished surface.
4. Storing units outside right-side up can cause the sunlight to discolor the finish. Also, unit becomes unstable and is easily knocked over by wind or bumping.
5. The backside of the shower unit is not water proof. Unit must be stored so that water will drain off of and not accumulate in any one spot. Water can permeate the back laminates and soak the glassed in wood supports causing bulges in the finished surface.
6. Never drag these units on any surface. Always transport the unit by hand using (2) people or a two-wheel dolly.
7. Never let these units drop from any height, not even an inch.
8. Never clean the shower finished surface with metal tools of any kind, including razors.

**** VERY IMPORTANT FOR SHOWERS WITH THRESHOLDS 2 INCHES OR LESS:**

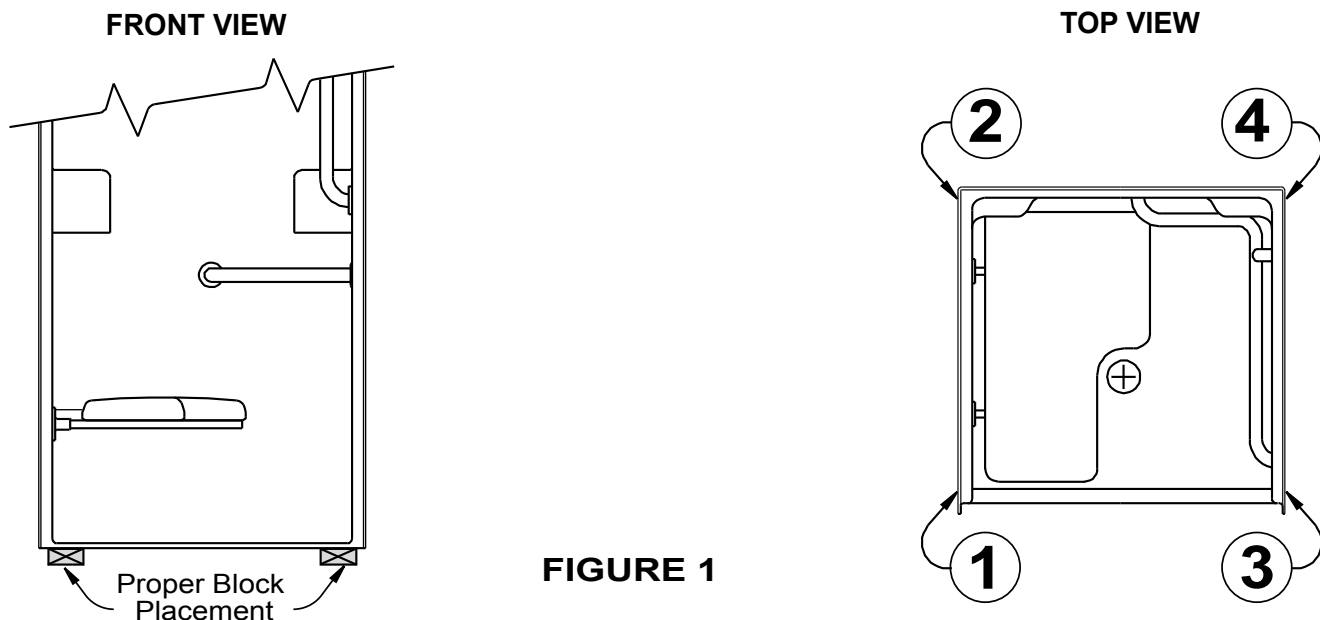

Shower stalls with thresholds of 2 inches or less must to be stored and installed with care. During storage this unit should sit as it is received. It should be store with a 2" x 4" block of some other type of material at each of the (4) points numbered above in the top view. These units do not have wooden bottoms to reinforce the floors as conventional showers have. By placing the unit on some type of blocking, the drain will not touch the floor. This will allow the draft of the floor to be maintained without the weight of the shower unit pushing the drain upward. The blocks should only be placed at the outside corner edges of the unit and should never be placed under the middle of the threshold. This procedure should only be used during storage and not during installation.

SHOWER THRESHOLD STYLES

ADA style showers have very specific code requirements. Showers with an inside Dimension of 36" are referred to as "Transfer Showers". Wheelchairs may roll up to these showers, and the occupant may "transfer" onto the seat of the shower. Since these showers are not large enough to roll a wheelchair into, the threshold height requirement is permitted to be 1/2 inch 90 degree vertical. Typically, these showers are installed directly on the sub floor with no pit or recess. This style is illustrated in Figure 2.

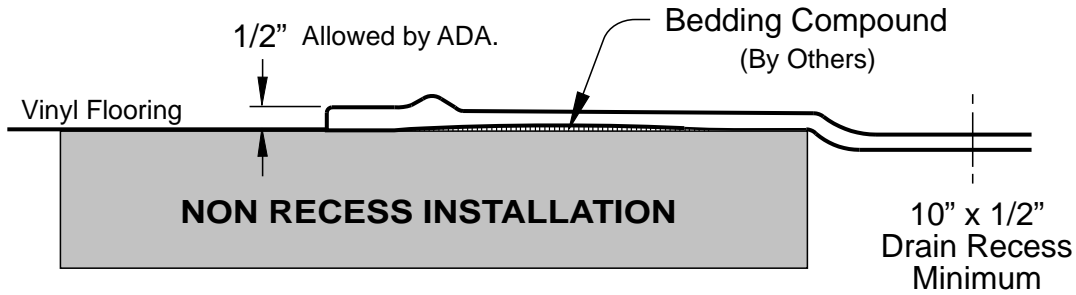

FIGURE 2

The alternate threshold style measures between 3/4 inch up to 2.0 inch 90 degree vertically. To comply with ADA requirements, these showers must be installed so the top of the shower entry is level with the finished flooring. These showers may be installed directly on the sub floor provided the finished floor is built up or a ramp is installed. Showers with threshold heights over one inch are usually installed into a recess or pit built into the sub floor. The depth of the recess should be calculated so the finished floor is level with the top of the threshold. See Figure 3.

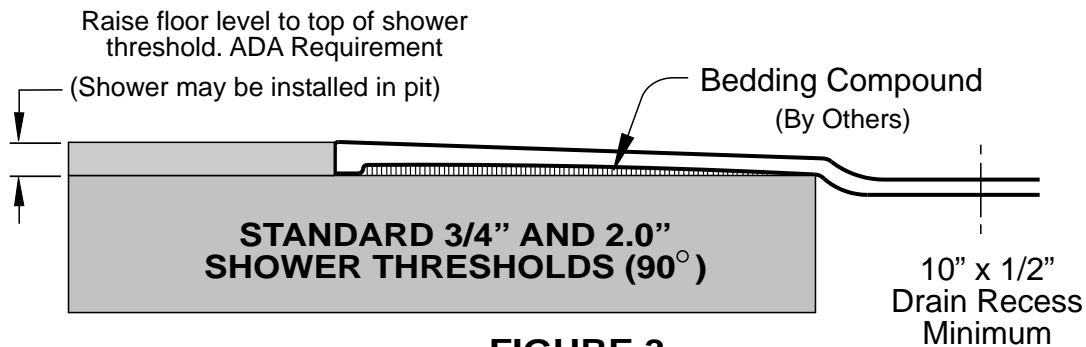

FIGURE 3

Every installation requires a 10 inch diameter x 1/2" deep recess around the drain core. This depth is necessary to assure the factory manufactured slope to the drain is maintained. Even if your installation is not ADA compliant, you will always need the 10 inch x 1/2 inch deep recess around the drain.

Thin set mortar must be used for support under all the installations.

DETAIL OF DRAIN CORE AREA

5" To 6" Diameter Drain Core Through Slab.

10" Diameter x 1/2" Deep Recess Around Core Minimum

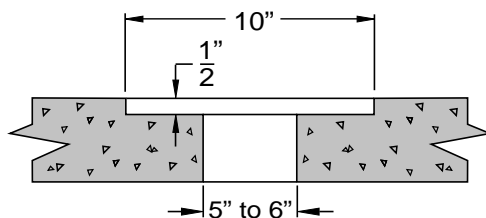

FIGURE 4

In order to ensure proper draining of the unit, it is advised to:

- (1) Core drill a diameter of 10" at a minimum depth of 1/2" on a concrete surface

-Or-

- (2) Box out a diameter of 10" at a depth of 1/2" around the drain pipe.

Following these instructions will allow the unit to drain properly.

This is absolutely necessary comply with product warranty requirements for proper installation.

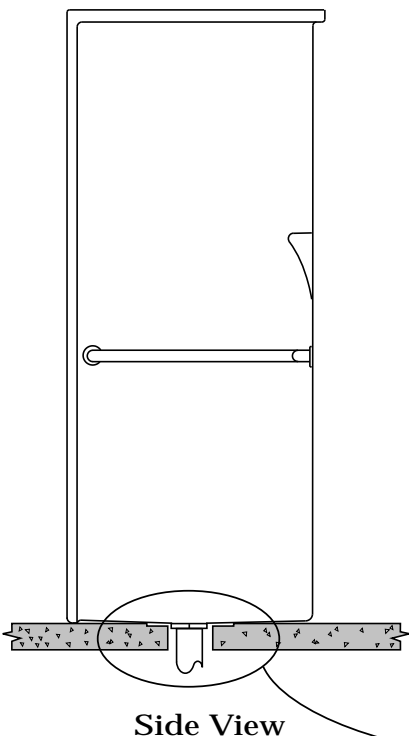

Side View

SHOWER THRESHOLD STYLES (con't.)

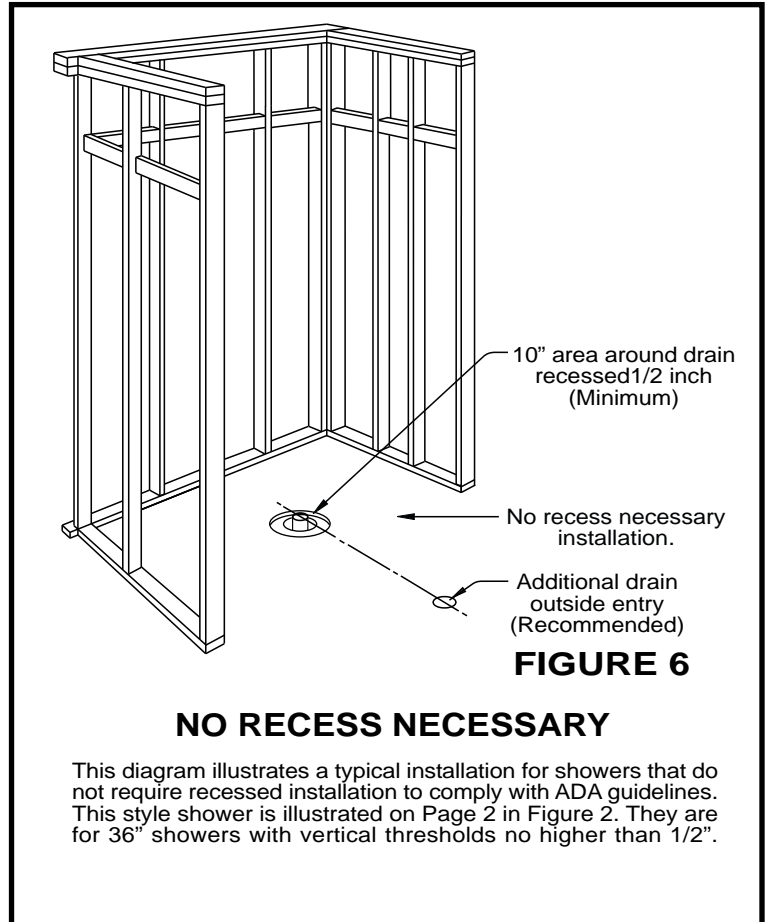
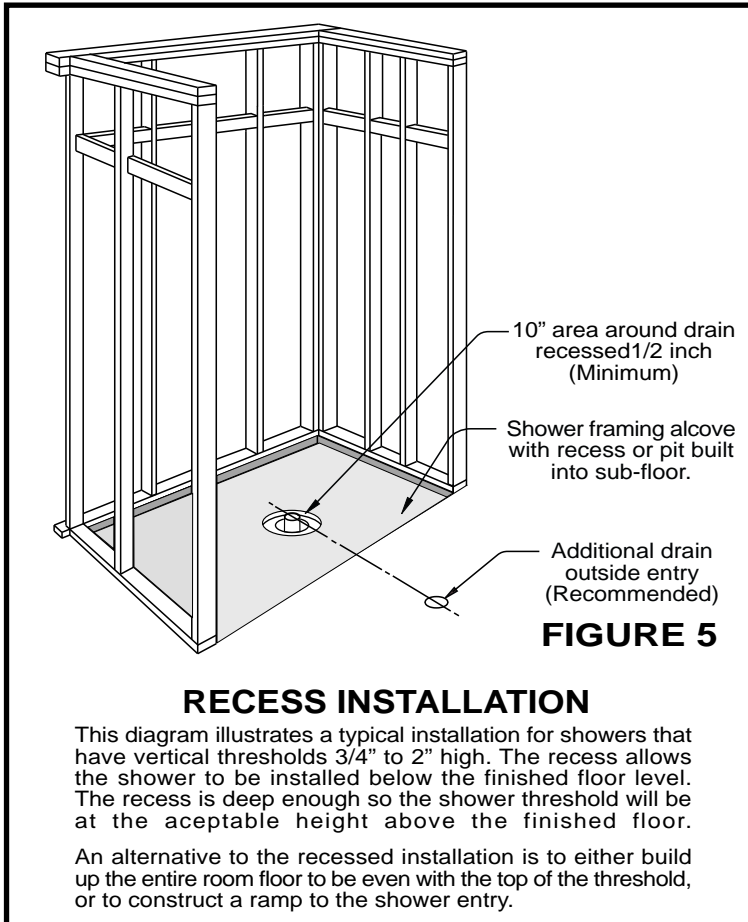

Whatever style shower you are installing, it is recommended that an additional drain be built into the room floor outside the shower. These showers have minimal slope to the floor and almost no dam to contain the shower spray. Water will often accumulate outside the shower and should be drained away.

SHOWER UNIT INSTALLATION

These instructions apply to all units whether they are installed directly on the floor slab or are recessed into a pit.

Note: We recommend that you conduct a demonstration requiring all installers to participate in for the 1st. shower unit installation to insure the remainder are installed properly.

1. Remove protective wood strips and cardboard used for shipping purposes.
2. Carefully tilt shower against a stud wall and remove the shipping and handling blocks from the underside of the shower.
3. Install no-caulk drain fitting. Do not install drain until shower is to be immediately installed. The shower should never be stood up right on a flat floor surface with drain attached. This will warp the shower and may void the warranty. (Figure 7.)
4. Prepare the drain pipe to receive the drain fitting.
5. Clean the installation area and underside of shower. Make sure the floor is free of grease, water and other contaminants that may affect adhesion.
6. If the shower you are installing has a threshold like the one shown in Figure 3, the vertical threshold is 3/4" to 2" tall. In most cases, these style units will be installed into a shallow recess or pit. The pit should have been prepared so when the unit is installed the finished room floor will be even with the top of the shower threshold. (ADA Code).
7. Mix "Thin Set" non-shrinking bedding compound into a thin soup like slurry. Praxis recommends Laticrete # 209 Floor Thin-Set Mortar.
8. Apply a 3/4" to 1" wide bead of 3M 560 polyurethane adhesive across the area of the sub floor where the threshold will rest. This will assist in adhering the bottom of the threshold to the sub floor.

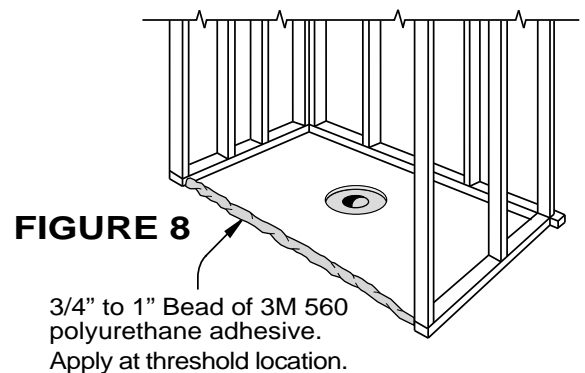
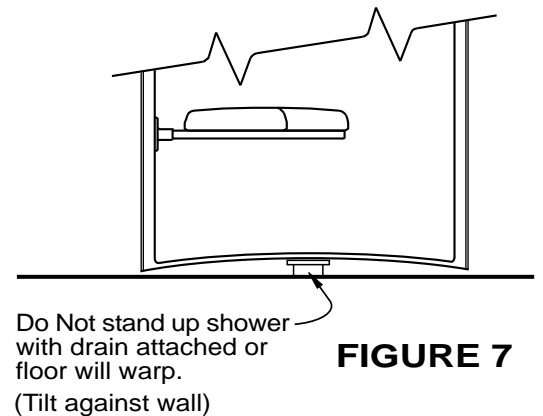

SHOWER UNIT INSTALLATION (CON'T.)

9. Apply the "Thin Set" a shovel full at a time using a 1/2" notched trowel estimating the amount needed to fill the small void between the floor and the unit. Use care not to disturb the bead of adhesive.

Note: The void can be as little as 1/16" in some areas. Excessive bedding compound will create high spots pushing the floor up causing the units to drain improperly.

Bulges or low spots must be corrected while the Thin-set is still wet.

10. Move shower to staging position in front of framing pocket, leaning the shower toward you. Temporary wood strips can be placed on the floor to allow the shower to slide into the pocket with less force. Slide the unit while tilted toward you until front edge of threshold is close to its permanent position.
If installing the shower into a pit, use great care not to drop the shower, but lower it into the installed position with care.
11. Stand shower up right. If necessary, place a hammer handle into the drain pipe to guide it into the drain fitting.
12. Check the threshold to make certain it has remained flat and has not bowed. If it is bowed, remove excess bedding compound and reset the unit. An additional temporary brace may be used, if required. (See Figure 11).
13. Plumb and level shower unit. Check floor for high spots or voids. Use a torpedo level on the floor. (Figure 10).

Note: If the floor is flexing, pull the unit up and add bedding compound. Should the barrier free threshold bow up in the middle on the front edge, check for excessive bedding compound or a tight framing pocket.

14. Secure the unit to the studs. Use self tapping screws. DO NOT USE NAILS.

15. Prepare and install ceiling brace. Measure and install 2 x 4 brace between ceiling and a wood block placed directly over the center of the drain, being careful not to scratch or damage the unit (See Figure 11). Carefully hammer and wedge brace into upright position pushing the drain area down into its proper position to achieve the correct slope ensuring proper drainage. Install brace on center of threshold in the same manner, if required.
16. Test the floor slope for proper drainage around the perimeter of the drain with a plumbers level or by pouring water around the perimeter of the shower floor. If the floor is firm with slope to the drain, your warranty is intact, you can leave the shower.
17. Remove braces after the bedding compound and adhesive has cured, (72 hours) checking floor again for high spots to ensure the slope has not been violated.

NOTE: All shower units are thoroughly tested to ensure the ability to drain water. Several tests are performed on each unit prior to it leaving the factory. Failure to follow the attached handling instructions and above installation procedures may cause improper drainage thus voiding the warranty. It is advised that all curb-less shower units should be fitted with water dam accessories such as a weighted curtain and/or collapsible or semi-permanent dam if the bath environment is not designed with an outside drain to catch any over spray of water that may escape the unit.

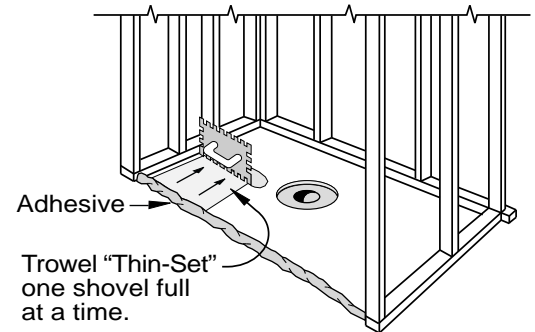

FIGURE 9

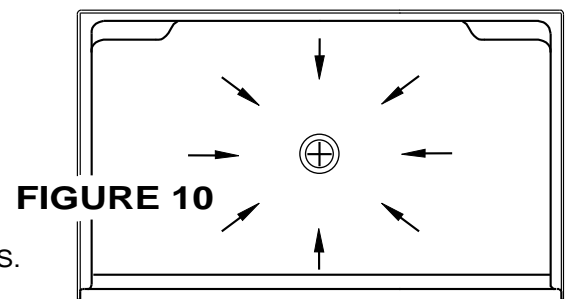
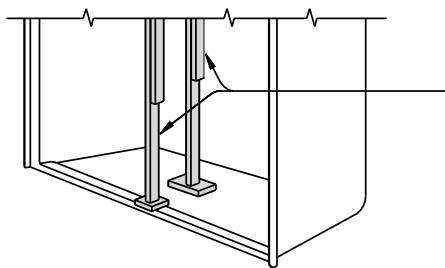

FIGURE 10



Temporary wood bracing for shower floor and threshold.
(Refer to Step 15)

FIGURE 11

Fill void using multi purpose thin set applied with a 1/2" notched trowel.

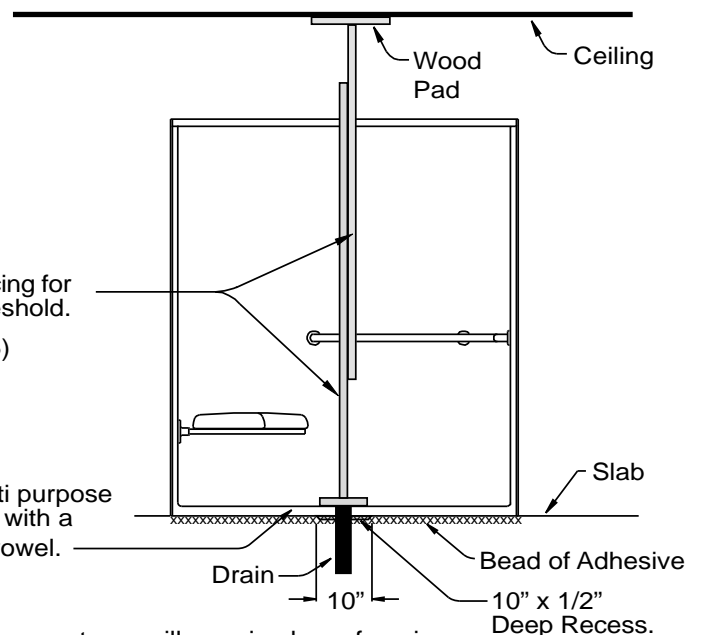

NOTE: Use thin-set ONLY when temperatures will remain above freezing.