

Pre-leveled and Reinforced Shower Pan Installation Instructions for Freedom ADA One Piece Showers

Tools & Materials you might need for proper installation

Materials:

- 2 - 1 gallon buckets of solid wood flooring adhesive (non-shrink)
- 20 - 1.25" wood screws
- 1 - 5 gallon bucket (to mix thin set in)
- 2 lb. bag of thin set (for the 10x10 box out)
- 1 - tube of non-shrink adhesive (for threshold)
- 1/8" shims (provided with the shower)
- 3 - 8' 2x4s
- 1 - 8" piece of 2x4
- 1 - 24" piece of 2x4
- 2 large soft cloths
- 3 gallons of water (for testing the draft to the drain and mixing thin set)
- Drain (provided with the shower)

Tools:

- Caulking gun
- 3/8" ratchet
- Hammer
- Drill

- 1/8" drill bit
- Screwdriver
- Screwdriver attachment to match screws
- 4' level
- 2' level
- Torpedo level
- Grout Mixer
- Black marker (to mark the threshold)

Helpful Hints for Installation:

- 2 - 5.5" pieces of PVC - These can be used to lay the product face down and roll it up to the framing pocket rather than sliding or picking it up.
- Please place cardboard from the carton into the bottom of the shower during installation to prevent damage to the finished surface.
- When placing shower into the frame pocket, you can use the handle of the hammer to align the pipe with the drain hole.

NOTE: INSTALLATION OF THESE SHOWER UNITS MAY BE SUBJECT TO CODE APPROVAL. Refer to job prints and/or consult with architect to see if your installation must comply with ADA.

These shower units install differently from typical residential showers. Installation may need to conform to requirements of the Americans With Disabilities Act (ADA) and other local codes. These requirements relate to the height of the threshold in relation to the finished floor. Certain showers will install directly on the sub floor and others will require a recess or pit. These showers require special preparation of the installation site, and very specific installation procedures to assure the shower drains properly and meets code requirements.

QUESTIONS? Please phone 1.800.759.7744 ext: 29 for additional information.

STORAGE & HANDLING

Do not store units out of doors.- Keep out of sunlight and exposure to weather.

1. Most handling damage is the result of impact blows to the back side of the shower units.
2. Stress cracks can develop when shipping boards are removed before unit is positioned for final installation in bathroom.
3. Placing objects inside of tub can cause scratches, abrasions or nicks to the finished surface.
4. Storing units outside right-side up can cause the sunlight to discolor the acrylic finish. Also, unit becomes unstable and is easily knocked over by wind or bumping.
5. The back side of the shower unit is not waterproof. Unit must be stored so that water will drain off of unit and not accumulate in any one spot. Water can permeate the back laminates and soak the glassed in wood supports causing bulges in the finished surface.
6. Never drag these units on any surface. Always transport the unit by hand using (2) people or a two-wheel dolly.

7. Never let these units drop from any height, not even an inch.
8. Never clean the shower finished surface with metal tools of any kind, including razors.

****Very Important for Showers with Thresholds 2 Inches or Less:** (See Figure 1)

Showers stalls with thresholds of 2 inches or less must to be stored and installed with care. During storage this unit should sit as it is received. It should be store with a 2" x 4" block of some other type of material at each of the (4) points numbered above in the top view. These units do not have wooden bottoms to reinforce the floors as conventional showers have. By placing the unit on some type of blocking, the drain will not touch the floor. This will allow the draft of the floor to be maintained without the weight of the shower unit pushing the drain upward. The blocks should only be placed at the outside corner edges of the unit and should never be placed under the middle of the threshold. This procedure should only be used during storage and not during installation.

RECESS I NSTALLATION

See Figure 2

This diagram illustrates a typical installation for showers that NO RECESS NECESSARY have vertical thresholds 3/4" to 2" high. The recess allows the shower to be installed below the finished floor level.

The recess is deep enough so the shower threshold will be at the acceptable height above the finished floor.

An alternative to the recessed installation is to either build up the entire room floor to be even with the top of the threshold, or to construct a ramp to the shower entry.

NO RECESS INSTALLATION

See Figure 3

This diagram illustrates a typical installation for showers that do not require recessed installation to comply with ADA guidelines. This style shower is illustrated in Figure 2. They are for 36" x 36" inside dimension showers with vertical thresholds no higher than 1/2".

SHOWER I NSTALLATION

NOTE: AT THE TIME OF INSTALLATION, INSURE THE FLOORING IS LEVEL. LEVEL FLOORING IN THE AREA INTENDED FOR INSTALLATION IS VERY IMPORTANT. IF THE FLOOR IS NOT LEVEL, THE OUTCOME OF THE INSTALLED UNIT COULD POSSIBLY RESULT IN DIFFICULTY WITH THE INSTALLATION. IN ADDITION, THE ARE A MUST BE CLEAN AND FREE OF DEBRIS AND MOISTURE.

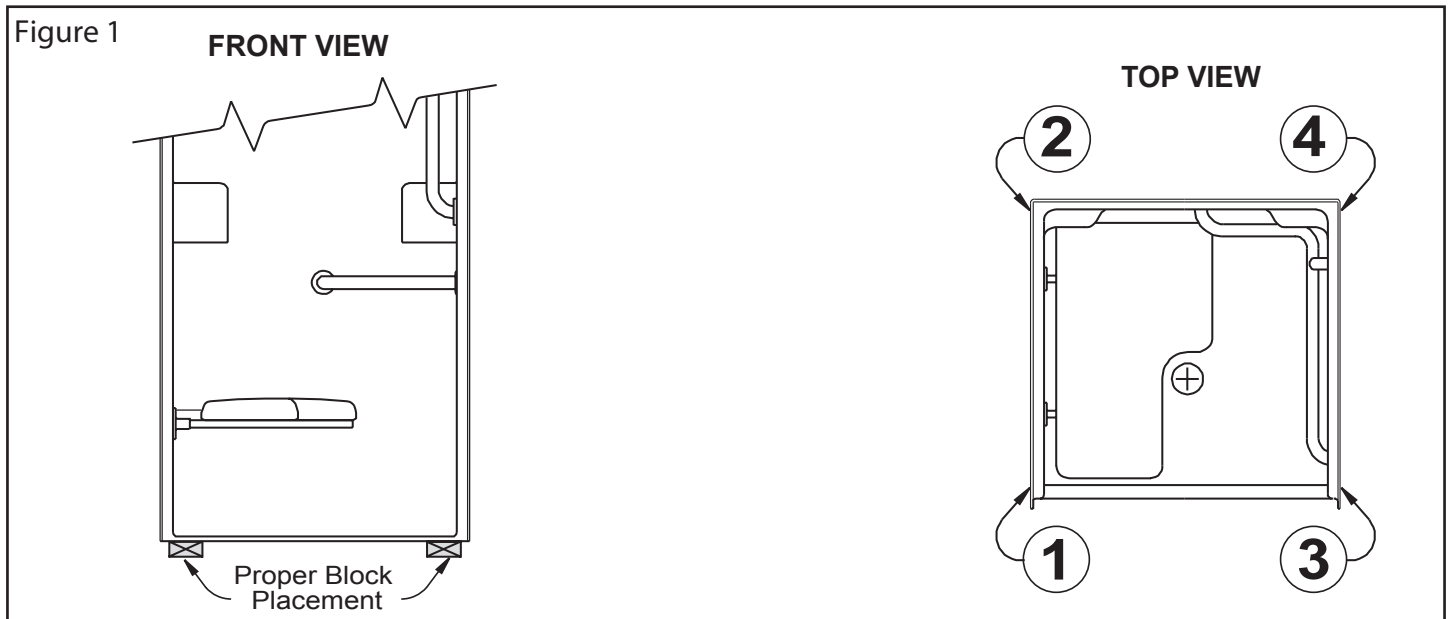

Figure 2

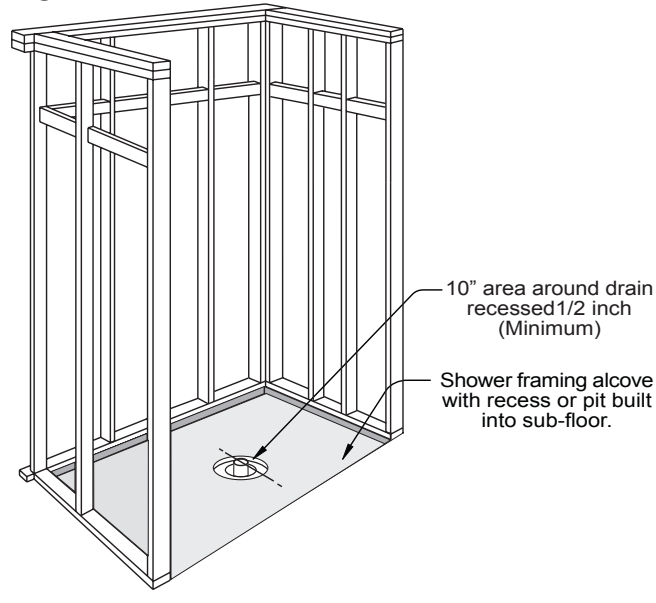
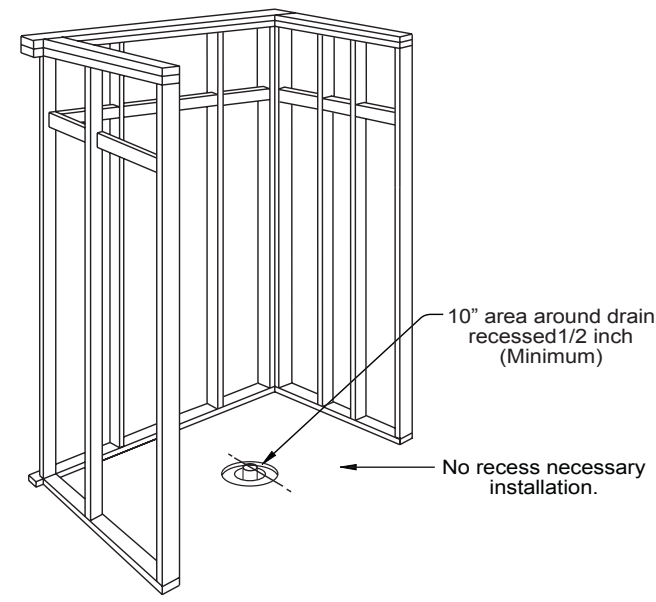

Figure 3



A 10" X 10" X 1/2" DEEP BOX OUT (10" CORE DRILL) IS REQUIRED TO BE CENTERED AROUND THE DRAIN PIPE. INSURE THIS AREA IS PREPARED BEFORE INSTALLATION. (See Picture 1)

1. Place the shower into the intended alcove to confirm proper placement of the drainpipe and sizing of the above. ****Helpful tip:** Place two sections of 1/2" PVC pipe on floor to help slide and tilt unit into position. (Remove PVC Pipe before proceeding to step 2. Draw a line on the floor where the front of the threshold lies.
2. Remove the shower from the alcove by leaning it forward, so that it can be laid on its front flanges.
3. Clean the area of all dirt, trash, oil, grease, water and other contaminants that may affect adhesion.
4. Apply Polyurethane Premium Construction adhesive or Liquid Nails to the floor and in a "zigzag" pattern with the space between the sides (line), around 1/2" wide. (See Picture 3)
5. Using a 1/4" trowel, wipe "across" the lines created in step 4. 100% coverage/contact of adhesive to Easy Base is required. (See Figure 4 & Picture 4)
6. Next, apply a continuous bead of Liquid Nails Construction adhesive or Polyurethane Premium Construction adhesive 1/2" wide x 3/8" thick x length to where the threshold of the shower will rest once the unit is installed.
7. Secure area around drainpipe with insulation for fire code and to prevent bedding compound from flowing down to the floor below. Fill the 10" x 10" x 1/2" box out (10" cure drill) area with a very wet non-shrink bedding compound 2/3 full. Do not over fill as this will prevent proper floor draft and may put the drain area up causing unit not to drain properly. (See Picture 2)
8. Install the drain provided in the shower prior to setting it into its final position, but do not store the shower on its bottom while the drain is installed. ****HELPFUL TIP: TEMPORARILY REMOVE DONUT SEAL.**
9. Set the shower into place and guide the drainpipe into the drain by using the handle of a hammer or similar object.
10. Level the shower and set plumb. If the floor is not level, it will require the use of shims to level the shower. (See Picture 5) If shims are required, they should be

placed no more than 6 inches apart to provide proper support.

DO NOT SHIM THE UNIT MORE THAN 1/8". If the shower requires more than 1/8" shim adjustment, the shower will need to be pulled out and the floor will need to be leveled. Insure the drain is lined up in the appropriate areas.

11. Secure the shower to the framing members through the flanges using 6D galvanized screws on 8" centers.

12. Cut a 2 x 4 member of 10" to place directly over the drain area. Cut a 2 x 4 member to extend from the ceiling to the 10" wooden block on the drain area. Protect the shower surface by placing a towel under the wooded block.

13. Place the brace from the ceiling to the 10" piece of wood. This should be a tight fit. (See Figure 5) continuous bead of Liquid Nails Construction adhesive.

14. Repeat steps 12 through 13, for the threshold, pressing it down to make complete contact with a continuous bead of Liquid Nails Construction adhesive.

15. A torpedo level should be placed from floor to insure the unit has proper slope and drainage. If unit does not drain properly, the unit must be pulled back up to determine where the problem lies. This should be done immediately after step 14 before the materials have had a chance to set.

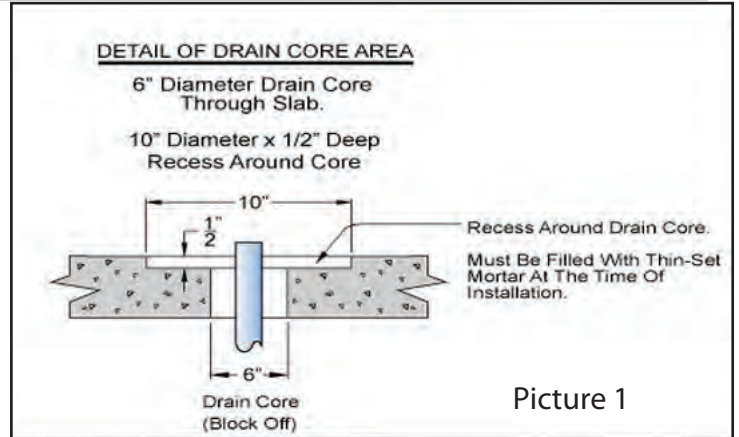
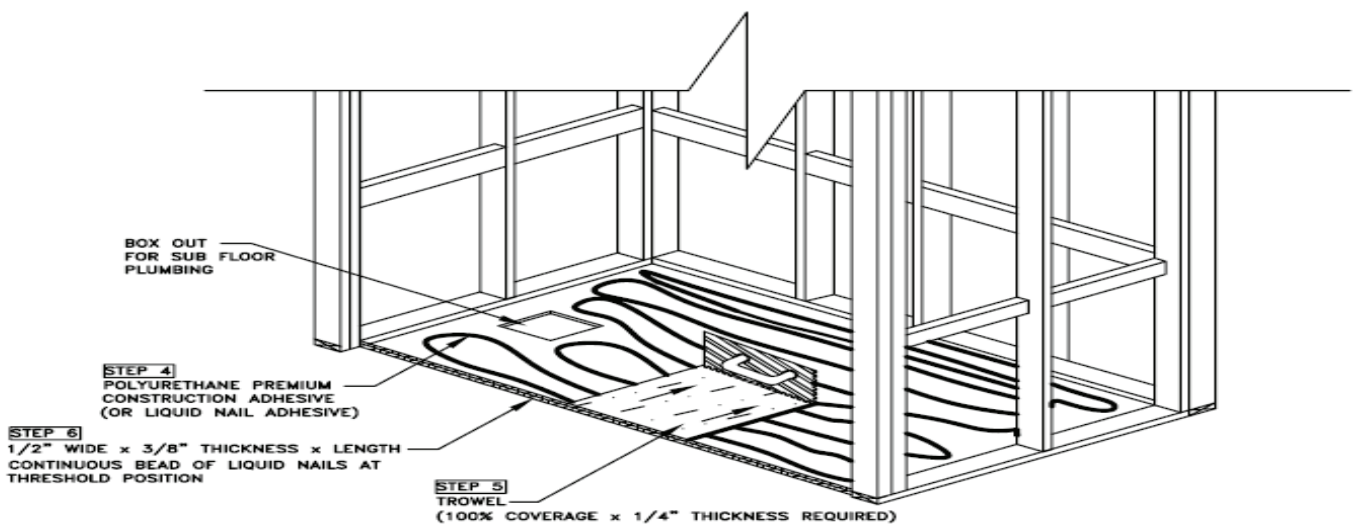
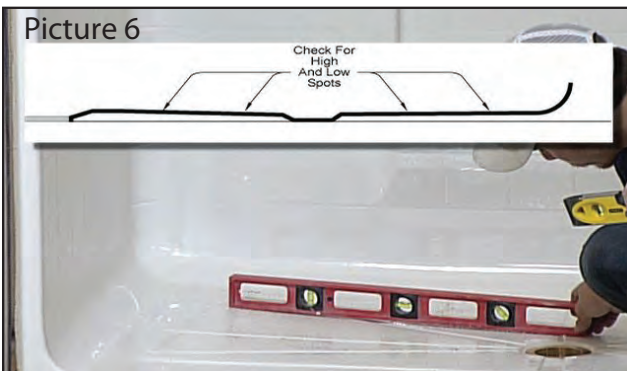
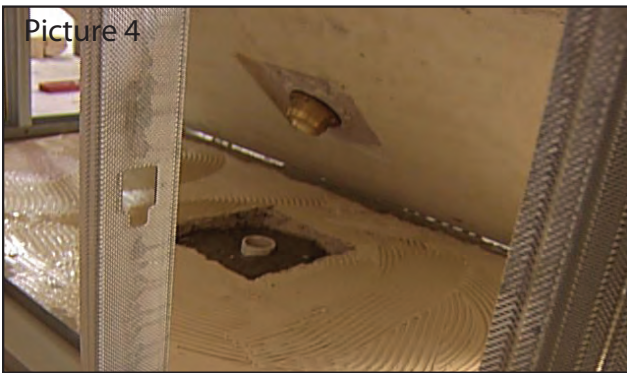

Figure 4

**ADHESIVE APPLICATION DETAIL
 ISOMETRIC SECTION VIEW**





16. Unit should be walked in and found to be stable and without flex.

17. All bracing can be removed after 72 hours after Liquid Nails Construction adhesive has been applied.

****THE DRAIN CONNECTION SHOULD BE TIGHTENED AFTER THE FLOOR HAS BEEN BRACED, CURED, AND THE BRACE REMOVED i.e. 72 HOURS AFTER INSTALL.**

****CHECK THE FLOOR TO INSURE THERE ARE NO HIGH SPOTS AND THE DRAFT HAS BEEN MAINTAINED. (See Picture 6)**

****ATTENTION: THE THRESHOLD MUST BE FLAT ACROSS THE FULL WIDTH WITH NO BOW AND LEVEL TO THE FLOOR.**

Following the appropriate installation procedures is imperative on this product. Not following these procedures could result in product failure which will not be covered under manufactures warranty.

